

## **SEBHSA Rolator RMC-60.OR**

- ❖ Replacing the old-fashioned bucket pouring of piles, the SEBHSA Rolator RMC-60.OR has been specifically designed for mega piles and deep foundation.
- ❖ The SEBHSA Rolator RMC-60.OR improves piling quality, operational efficiency and safety for the very biggest jobs adding value to the world mega projects.
- ❖ The SEBHSA Rolator RMC-60.OR has been perfectly configured to complement any kind of drilling rig while being fed by SEBHSA's biggest crawler-mounted concrete pump BD-4147.OR.



### **Technical specifications:**

Diesel Engine:	55 kW
Track length:	3.450 mm
<b>Dimensions:</b>	
Width	2.300 mm
Length	6.200 mm (with arm extended)
Height	2.500 mm (in position of transport)
Hose on Rolator:	6´
Usable hose length:	50 m
Fuel tank capacity:	80 l

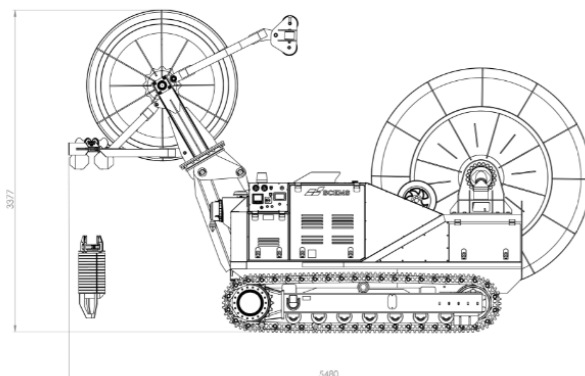
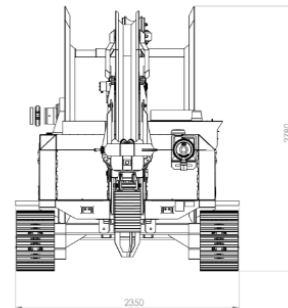
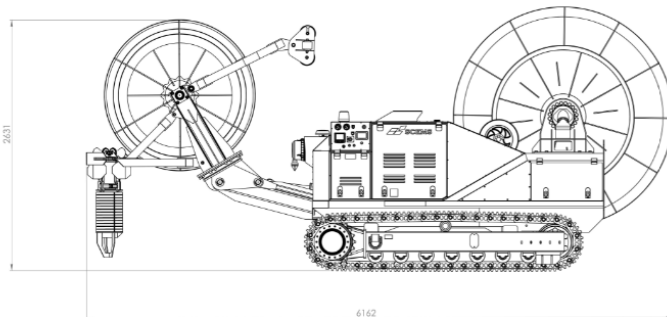

### **Typical included accessories & fit-outs:**

- High pressure water pump
- Water tank
- 2x Radio remote controls for crawler movement and roll-up/down function
- All connectors & terminals to fit SEBHSA crawler-mounted concrete pumps